



GUILDFORD  
B O R O U G H

[www.guildford.gov.uk](http://www.guildford.gov.uk)

**Tom Horwood**  
Joint Chief Executive of Guildford and  
Waverley Borough Councils

Dear Councillor

**PLANNING COMMITTEE - MONDAY 21 MARCH 2022**

Please find attached the following:

**Agenda No    Item**

8.     **Presentations (Pages 1 - 90)**

Yours sincerely

Sophie Butcher, Democratic Services Officer

Encs

This page is intentionally left blank

**20/P/01057**

**White Horse Yard  
High Street  
Ripley  
GU23 6BB**

[Previous](#)

[Next](#)

[Home](#)



Ordnance Survey (c) Crown Copyright 2018. All rights reserved. Licence number 100022432

Location Plan

[Previous](#)

[Next](#)

[Home](#)









Location Plan Showing Nearby Listed Buildings

[Previous](#)

[Next](#)

[Home](#)





Front Elevation



Side Elevation



Rear Elevation



Side Elevation



Ground Floor Plan

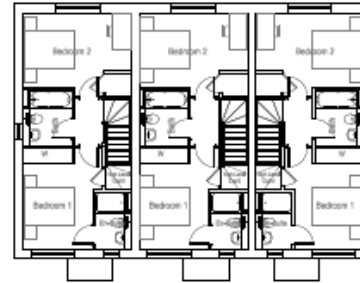

First Floor Plan



Front Elevation

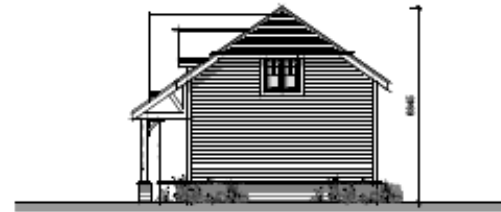

Side Elevation



Rear Elevation



Side Elevation



Ground Floor Plan

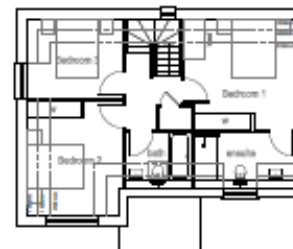

First Floor Plan



Front Elevation



Side Elevation



Rear Elevation

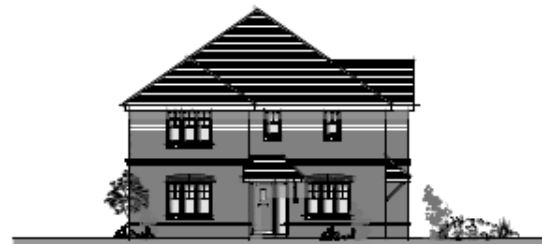

Side Elevation

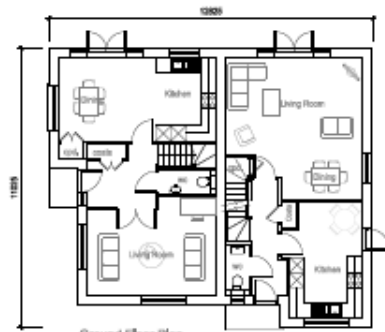

Ground Floor Plan



First Floor Plan



Front Elevation

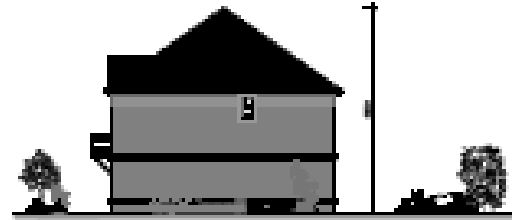

Side Elevation



Rear Elevation



Side Elevation

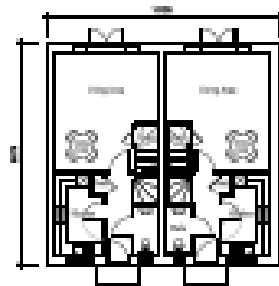

Ground Floor Plan

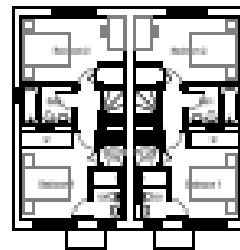

First Floor Plan



Front Elevation



Side Elevation



Rear Elevation



Side Elevation

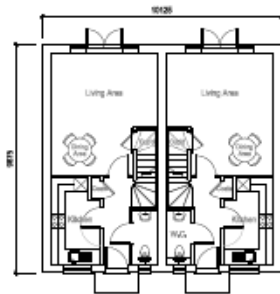

Ground Floor Plan

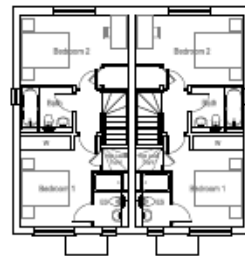

First Floor Plan



Front Elevation

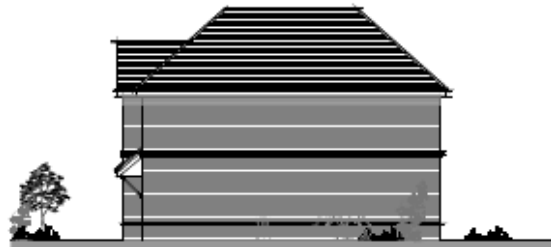

Side Elevation



Rear Elevation

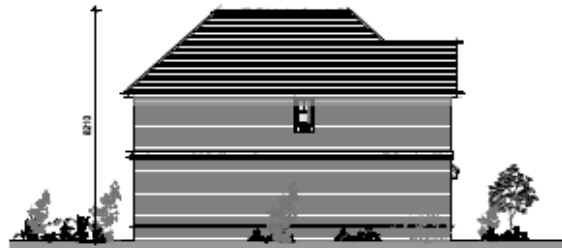

Side Elevation



Ground Floor

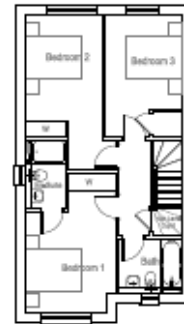

First Floor



Front Elevation



Side Elevation



Rear Elevation

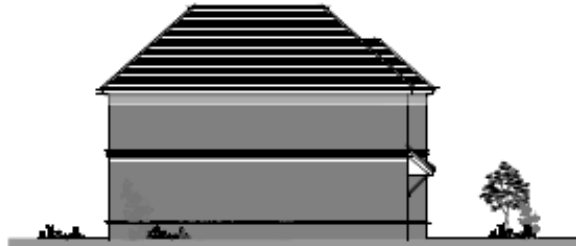

Side Elevation



Ground Floor



First Floor



Front Elevation

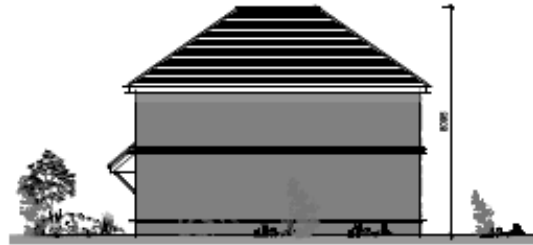

Side Elevation



Rear Elevation



Side Elevation



Ground Floor



First Floor





Front Elevation

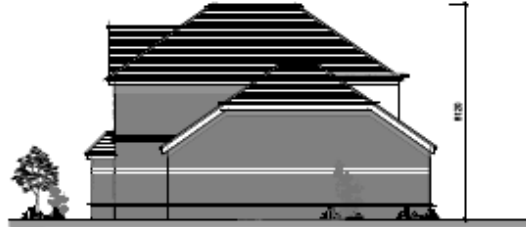

Side Elevation



Rear Elevation



Side Elevation

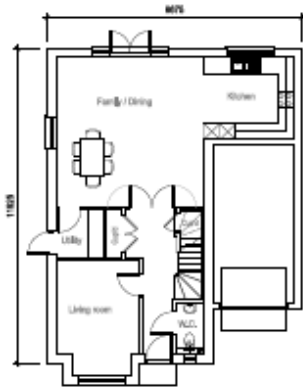

Ground Floor



First Floor



Front Elevation

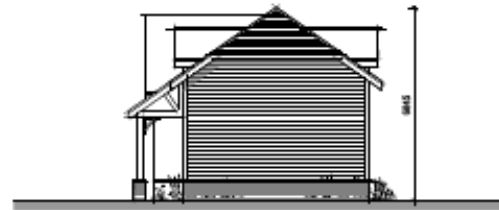

Side Elevation



Rear Elevation



Side Elevation

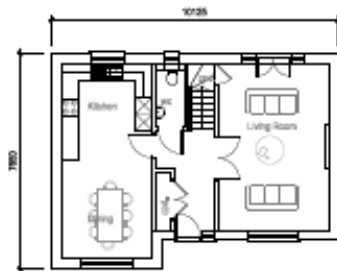

Ground Floor Plan



First Floor Plan

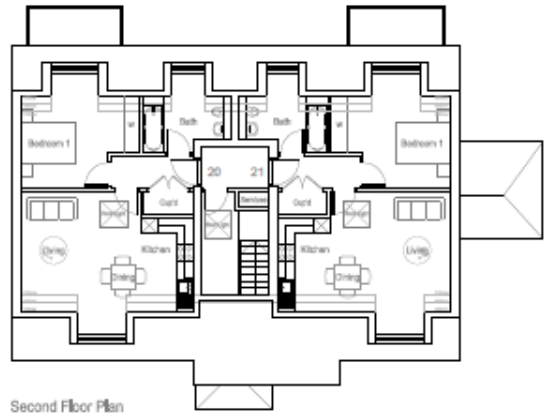

Second Floor Plan

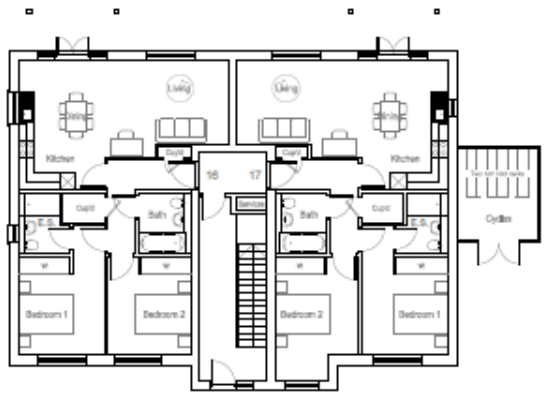

Ground Floor Plan

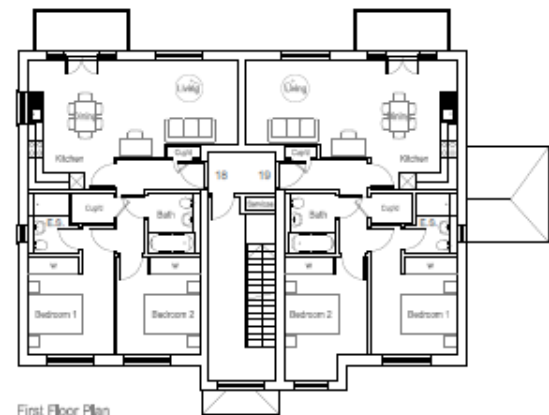

First Floor Plan



Front Elevation



Side Elevation



Rear Elevation



Side Elevation



Front Elevation

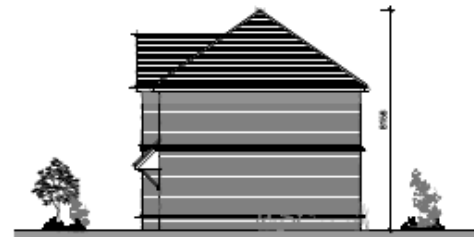

Side Elevation



Rear Elevation



Side Elevation

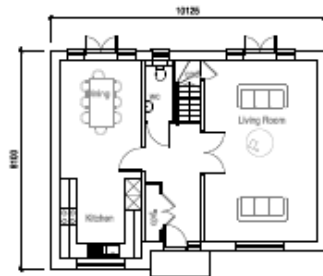

Ground Floor Plan



First Floor Plan

### Plot 22 & 23 Plans & Elevations

[Previous](#)

[Next](#)

[Home](#)



Front Elevation



Side Elevation



Rear Elevation



Side Elevation

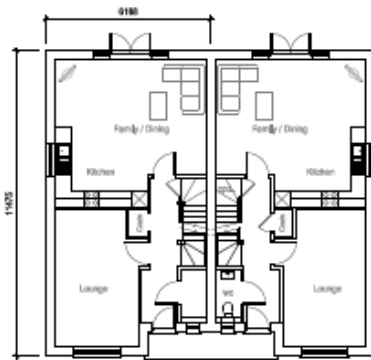

Ground Floor Plan

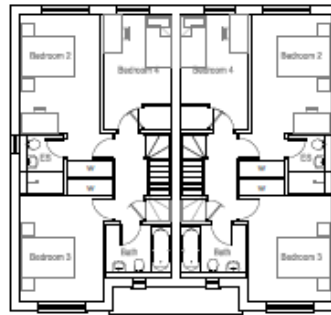

First Floor Plan

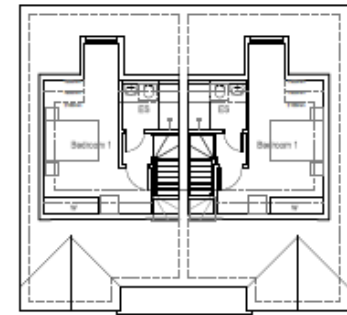

Second Floor Plan

**Plots 24 & 25 Plans & Elevations**

[Previous](#)

[Next](#)

[Home](#)



Front Elevation

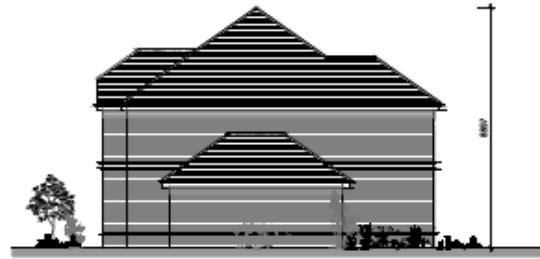

Side Elevation



Rear Elevation



Side Elevation

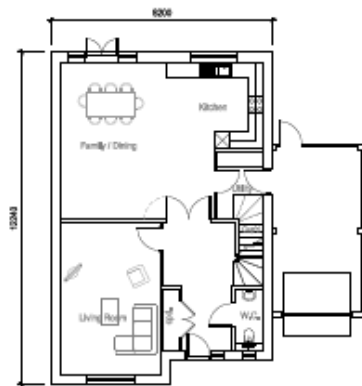

Ground Floor Plan

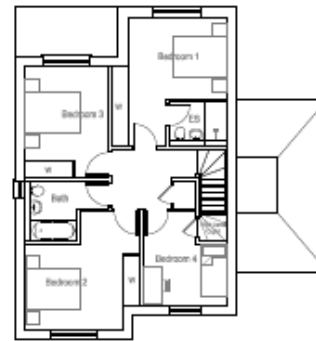

First Floor Plan

## Plot 26 Plans & Elevations

[Previous](#)

[Next](#)

[Home](#)

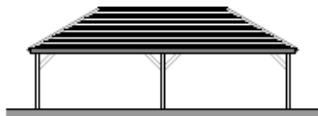

Front Elevation

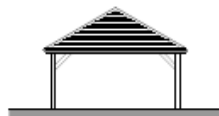

Side Elevation

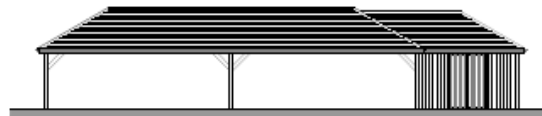

Front Elevation



Side Elevation

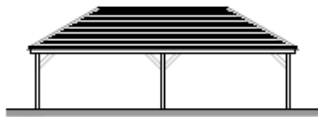

Rear Elevation

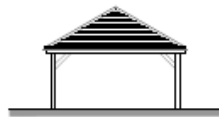

Side Elevation



Rear Elevation

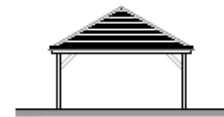

Side Elevation



Plan

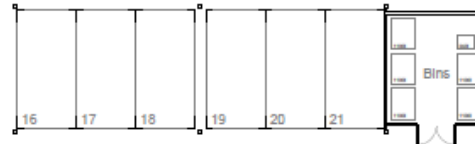

Plan





[Previous](#)

[Next](#)

[Home](#)



[Previous](#)

[Next](#)

[Home](#)



[Previous](#)

[Next](#)

[Home](#)



[Previous](#)

[Next](#)

[Home](#)

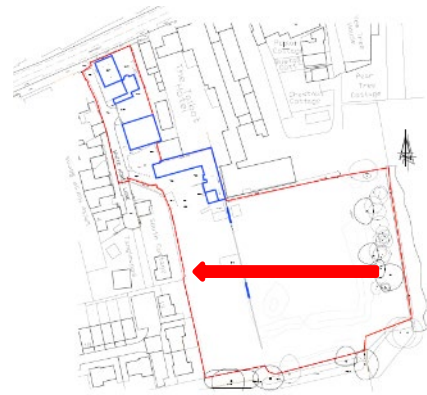

[Previous](#)

[Next](#)

[Home](#)



[Previous](#)

[Next](#)

[Home](#)



[Previous](#)

[Next](#)

[Home](#)



[Previous](#)

[Next](#)

[Home](#)



**20/P/01058**

**White Horse Yard  
High Street  
Ripley  
GU23 6BB**

[Previous](#)

[Next](#)

[Home](#)



Ordnance Survey (c) Crown Copyright 2018. All rights reserved. Licence number 100022432





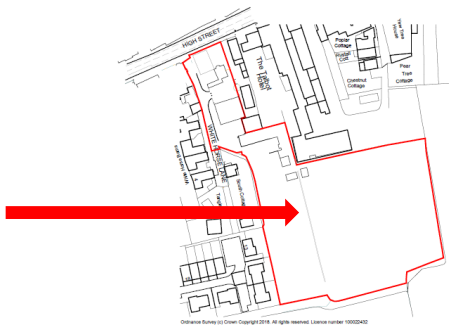

[Previous](#)

[Next](#)

[Home](#)

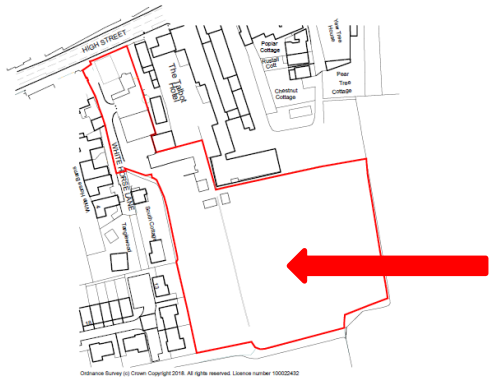

[Previous](#)

[Next](#)

[Home](#)

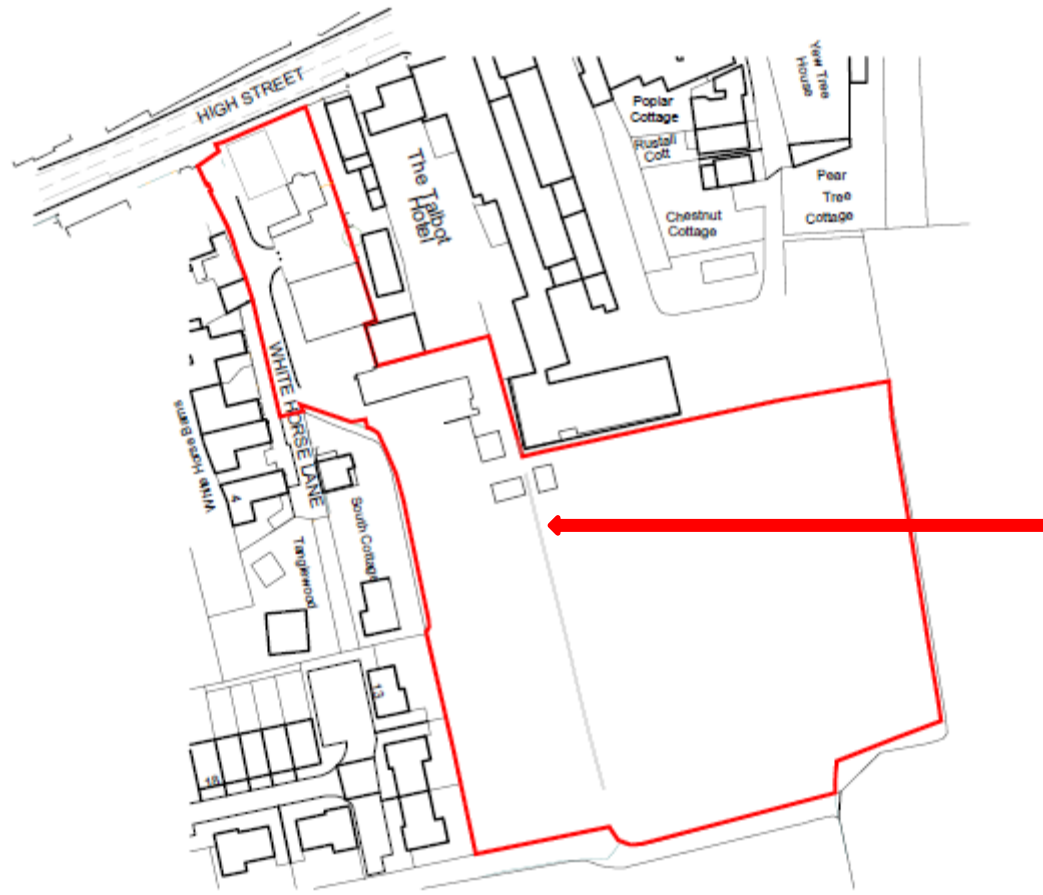

Ordnance Survey (c) Crown Copyright 2018. All rights reserved. Licence number 100022432

This page is intentionally left blank



**21/P/00428**

**Howard Of Effingham School**

**Lower Road**

**Effingham**

**Leatherhead**

**KT24 5JR**

[Previous](#)

[Next](#)

[Home](#)



Aerial photo

[Previous](#)

[Next](#)

[Home](#)

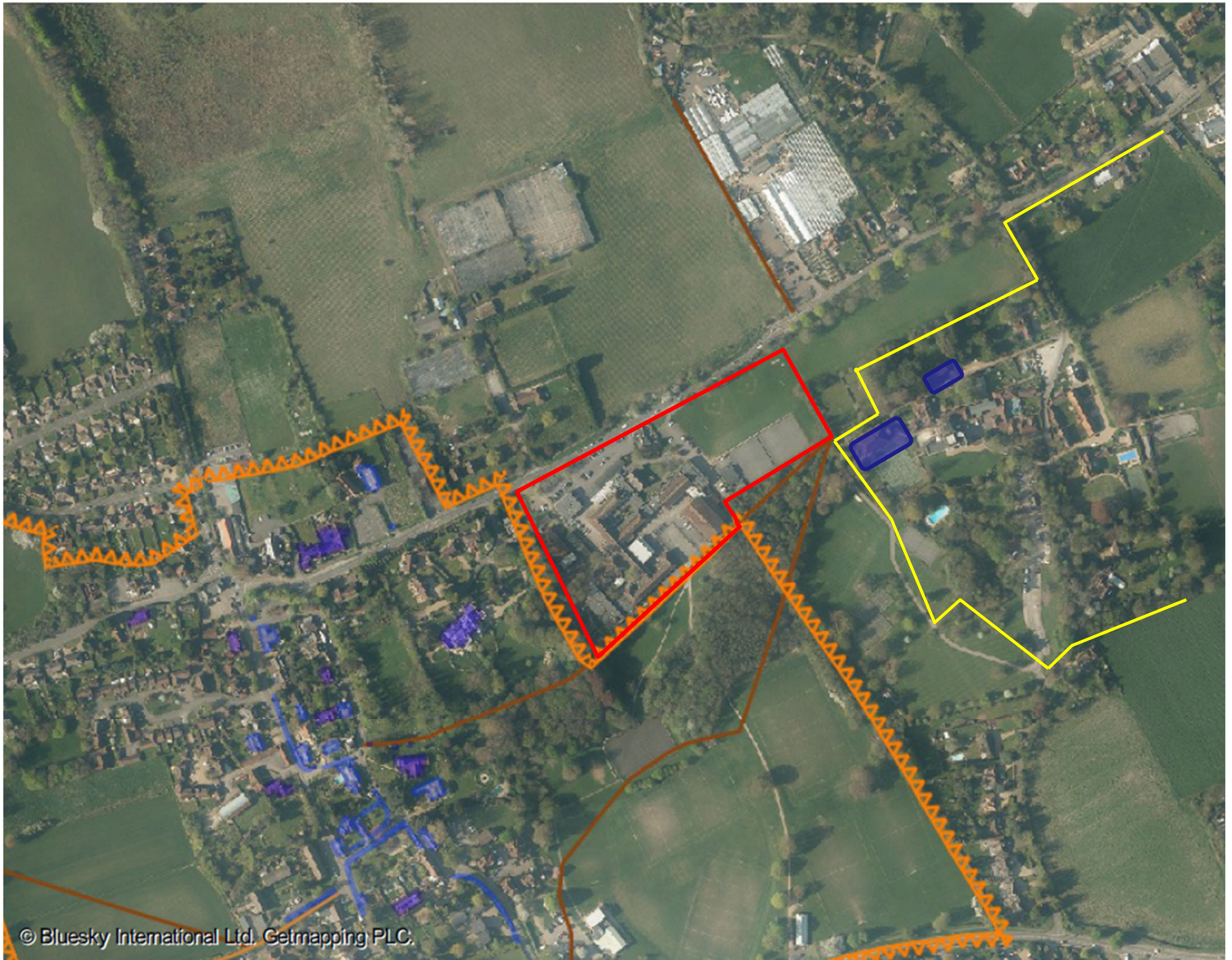

**Constraints**

**Previous**

**Next**

**Home**



Approved appeal masterplan

[Previous](#)

[Next](#)

[Home](#)



Approved indicative  
masterplan

Previous

Next

Home

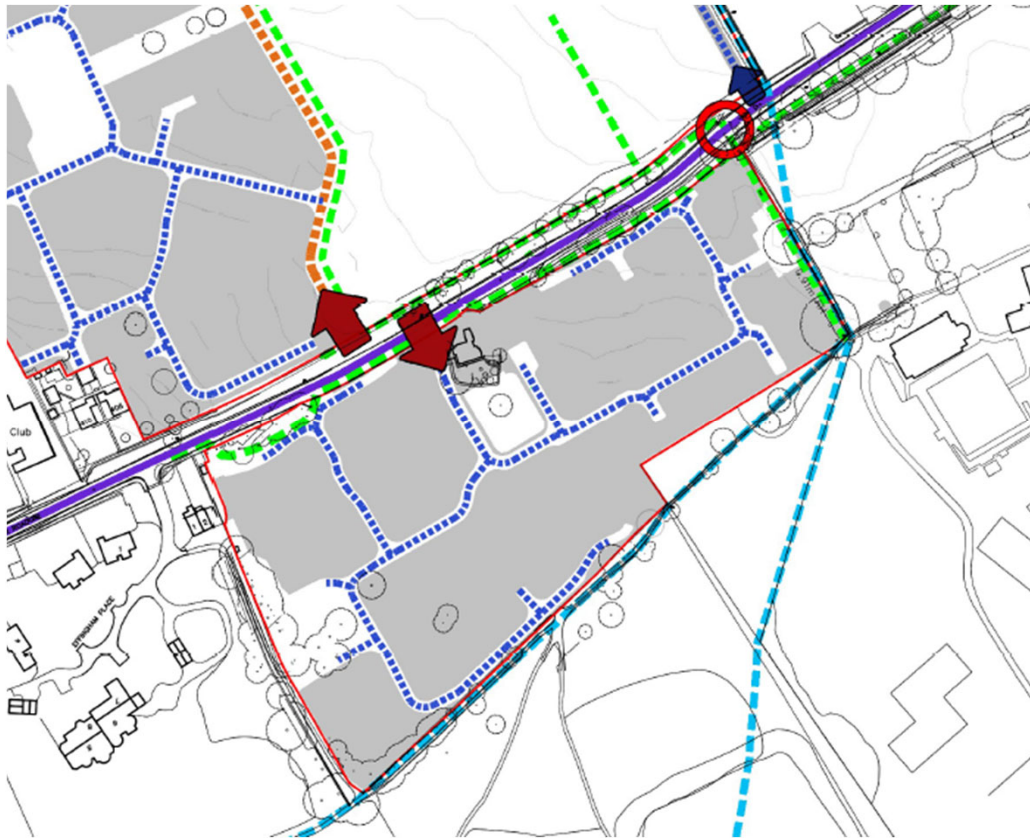
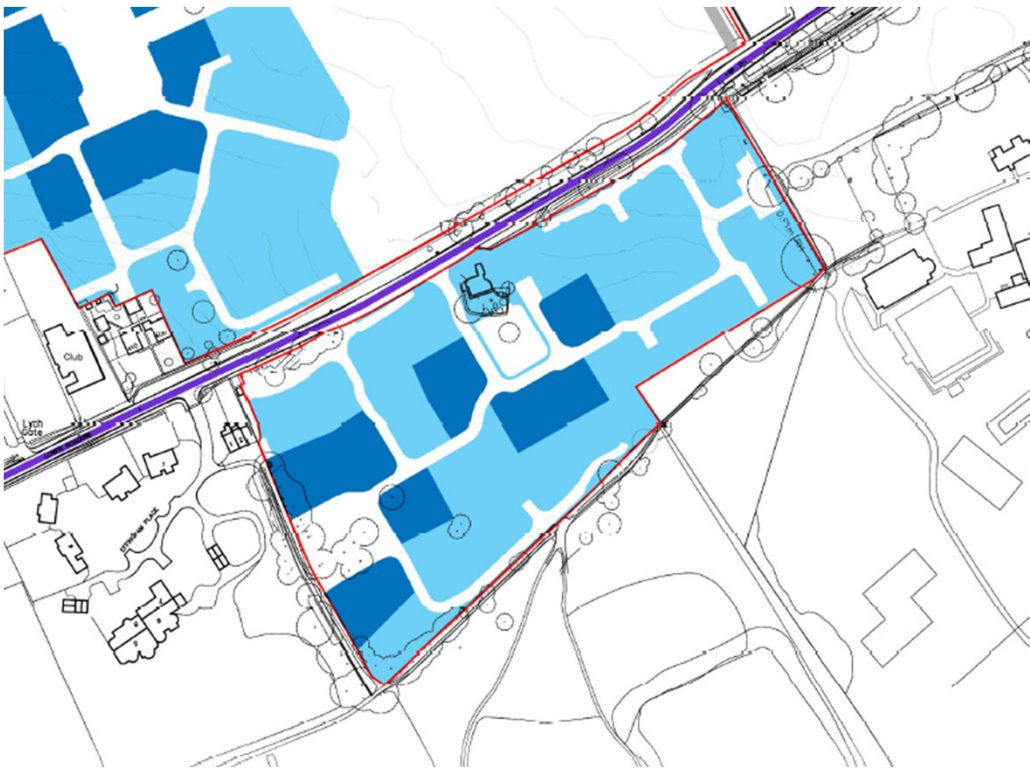

Approved indicative parameter plans



**Proposed site layout plan**

[Previous](#)

[Next](#)

[Home](#)



**Proposed and approved  
masterplans**

**Previous**

**Next**

**Home**



3BH(R - Wheelchair)  
Plot 62

3BH(R - Accessible)  
Plot 61

3BH(R - Wheelchair)  
Plot 60



Front Elevation

N4H11  
Plot 87



Front Elevation

N5H2  
Plot 35



Front Elevation

N4H31  
Plot 80



Front Elevation



Front Elevation



Side Elevation



Front Elevation





(street scene B-B)



(street scene C-C)



Lower Road (street scene A-A)



Indicative streetscenes

Previous

Next

Home

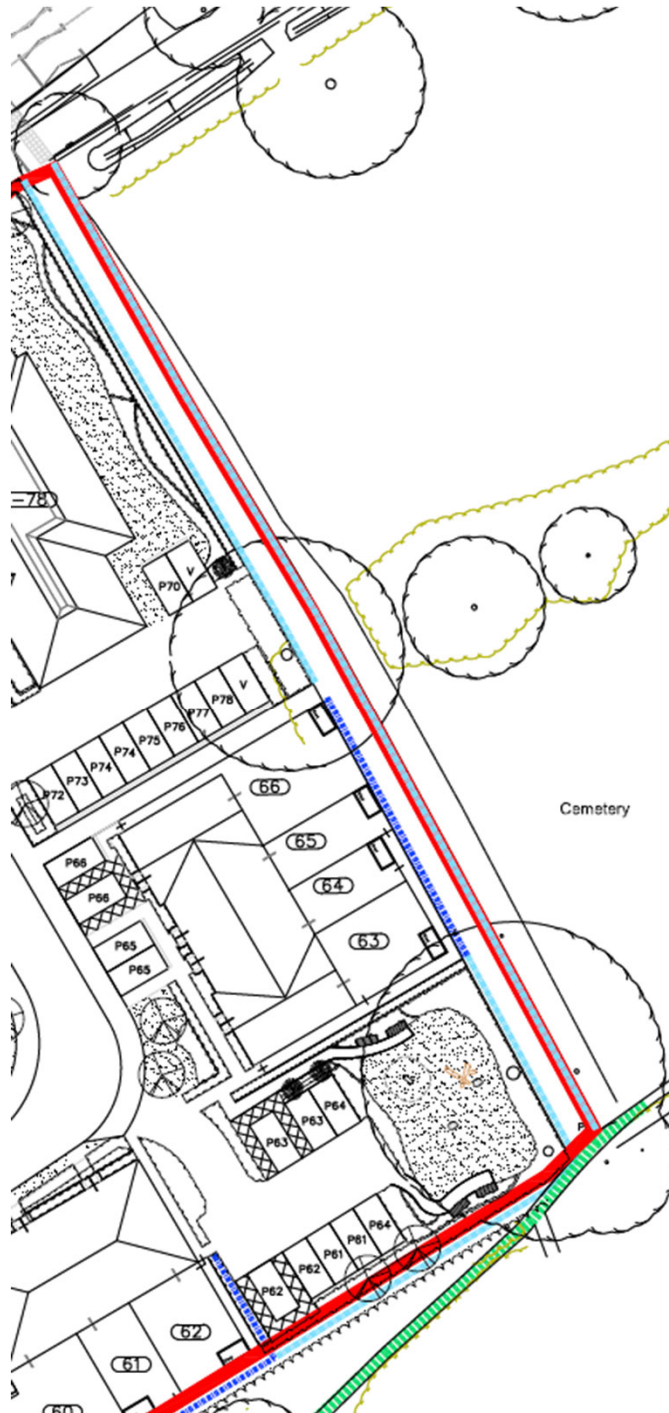

— Proposed Boundary  
- - - - - Existing Public Right of Way  
 Proposed Fencing to replace existing public fence and to locate along the boundary through existing and proposed vegetation



— Proposed 1.2m high vertical bar railing with square top, 100mm wide



- - - - - Proposed stone board fencing to new gardens

Eastern boundary



Previous

Next

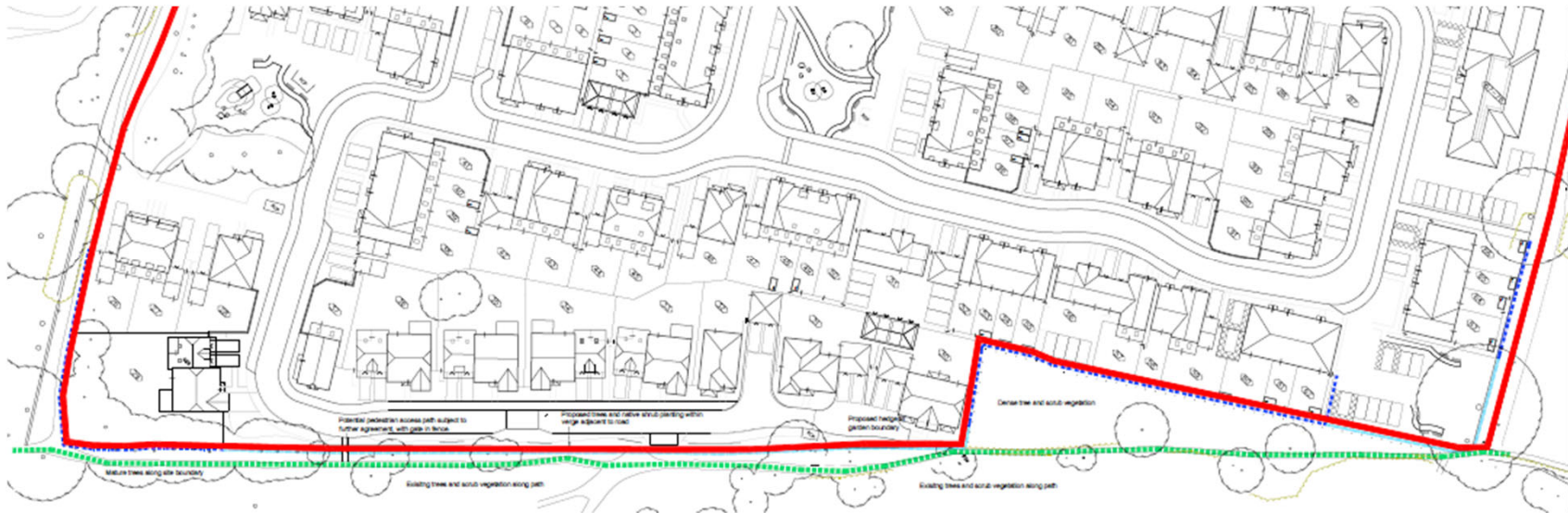
Home



— Application boundary  
- - - - Existing public right of way  
- - - - Proposed fencing to replace existing cast-iron fence and be located along site boundary alongside existing and proposed vegetation  
- - - - Proposed 1.5m high vertical bar railing with sphere top, finished black  
- - - - Proposed close board fencing to rear garden

Southern boundary

Previous

Next

Home



[Previous](#)

[Next](#)

[Home](#)





[Previous](#)

[Next](#)

[Home](#)



[Previous](#)

[Next](#)

[Home](#)



[Previous](#)

[Next](#)

[Home](#)



## Site Layout Plan

[Previous](#)

[Next](#)

[Home](#)

**21/P/00976**

**Lot 5**

**Land To The West Of  
Manor Farm Cottage  
Westwood Lane  
Wanborough  
Guildford**

[Previous](#)

[Next](#)

[Home](#)





© Bluesky International Ltd, Getmapping PLC

**Aerial view**

**Previous**

**Next**

**Home**







[Previous](#)

[Next](#)

[Home](#)

This page is intentionally left blank

**21/P/01456**

**Land At  
Poyle Road  
Tongham  
Guildford**

[Previous](#)

[Next](#)

[Home](#)



# POYLE ROAD, TONGHAM



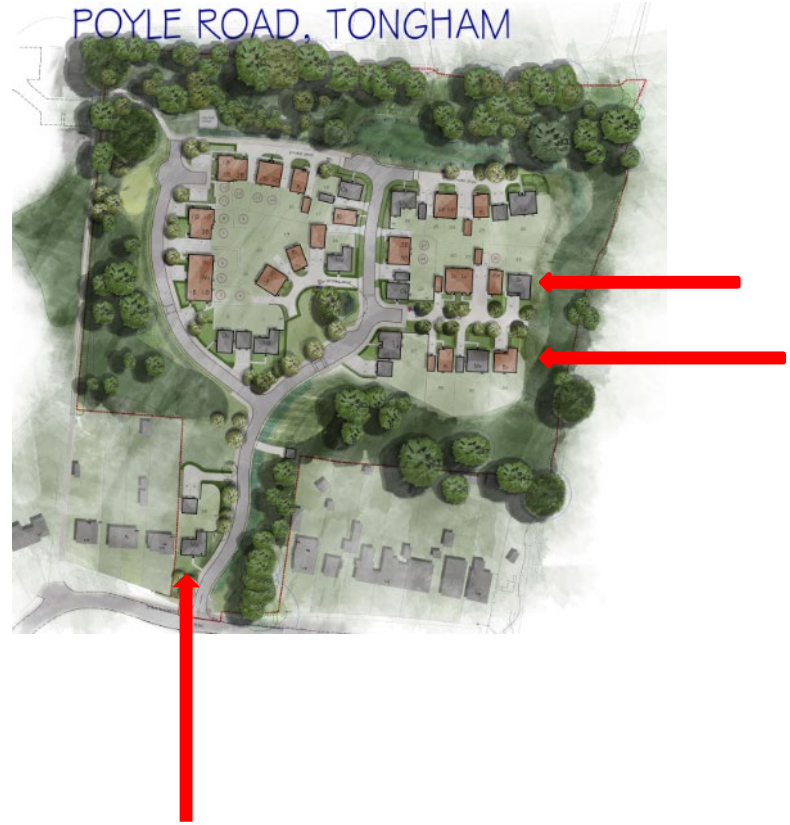



Front Elevation

Side Elevation



Rear Elevation

Side Elevation



Front Elevation

Side Elevation



Rear Elevation

Side Elevation





FRONT ELEVATION

FRONT/SIDE ELEVATION



SIDE ELEVATION

REAR ELEVATION



HOUSE TYPE 1B  
FRONT / SIDE ELEVATION

HOUSE TYPE 1B

HOUSE TYPE WU  
FRONT ELEVATION

HOUSE TYPE WU

HOUSE TYPE 1B



HOUSE TYPE WU  
SIDE ELEVATION

HOUSE TYPE 1B  
REAR ELEVATION

HOUSE TYPE WU

HOUSE TYPE WU



HOUSE TYPE 2B  
FRONT ELEVATION

HOUSE TYPE 2B

HOUSE TYPE 2B  
SIDE ELEVATION



HOUSE TYPE 2B  
REAR ELEVATION

HOUSE TYPE 2B

HOUSE TYPE 2B  
SIDE ELEVATION



FRONT ELEVATION

SIDE ELEVATION



REAR ELEVATION

SIDE ELEVATION



HOUSE TYPE 1B  
FRONT / SIDE ELEVATION

HOUSE TYPE 1B

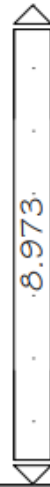

HOUSE TYPE 3B  
FRONT ELEVATION

HOUSE TYPE 1B

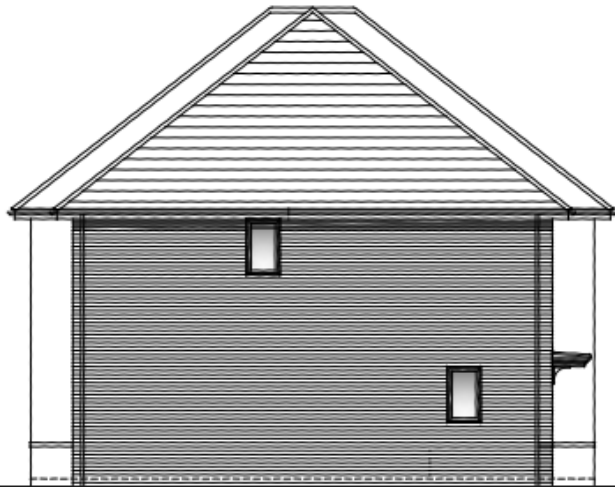

HOUSE TYPE 3B  
SIDE ELEVATION



HOUSE TYPE 1B  
REAR ELEVATION

HOUSE TYPE 3B



Front Elevation

Side Elevation



Rear Elevation

Side Elevation



FRONT ELEVATION

SIDE ELEVATION



REAR ELEVATION

SIDE ELEVATION



Front Elevation

Side Elevation



Rear Elevation

Side Elevation



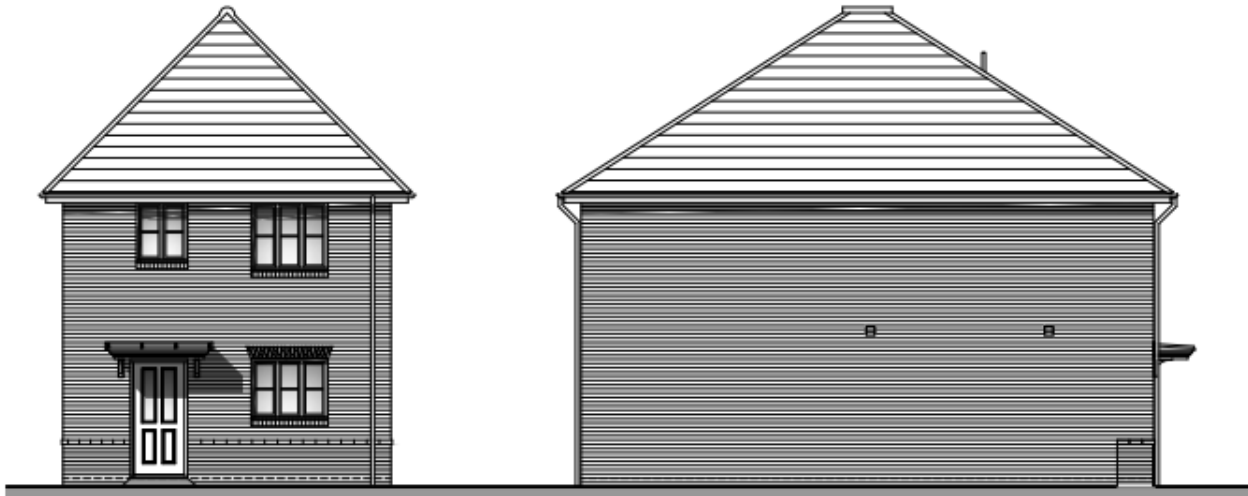

FRONT ELEVATION

SIDE ELEVATION



REAR ELEVATION

SIDE ELEVATION



Front Elevation

Side Elevation

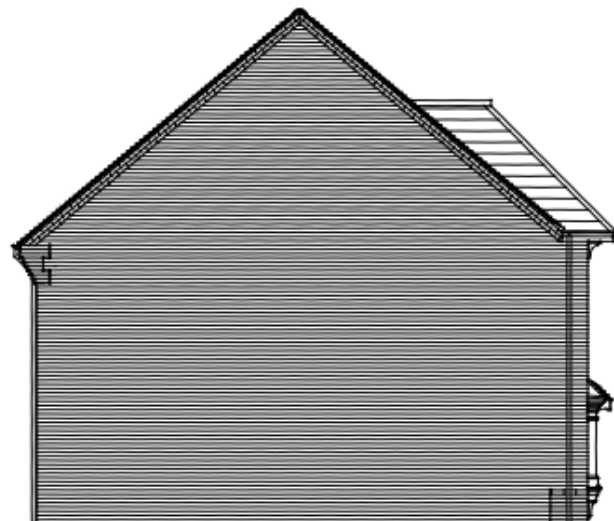



Front Elevation

Side Elevation



Rear Elevation

Side Elevation

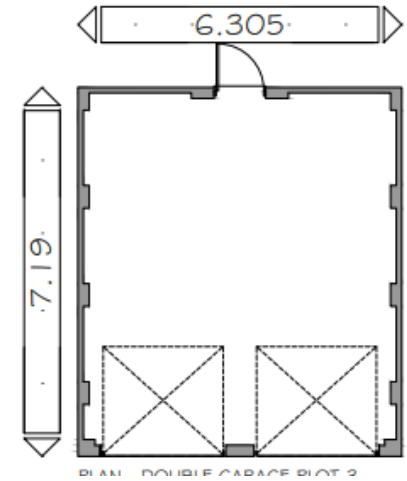
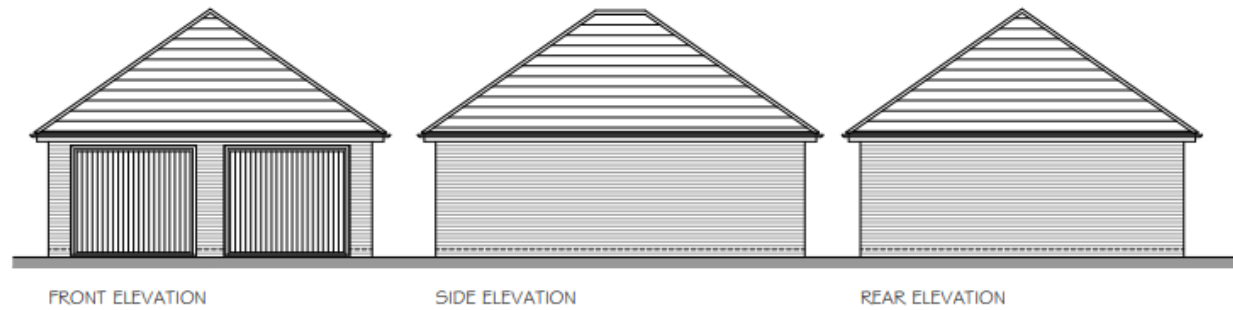
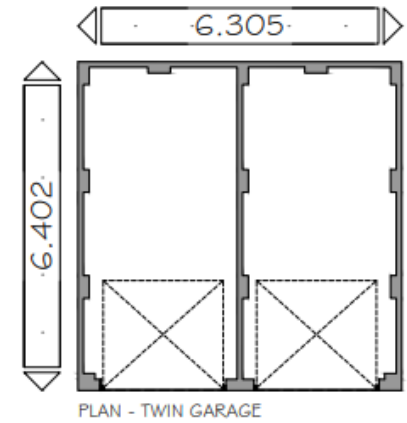
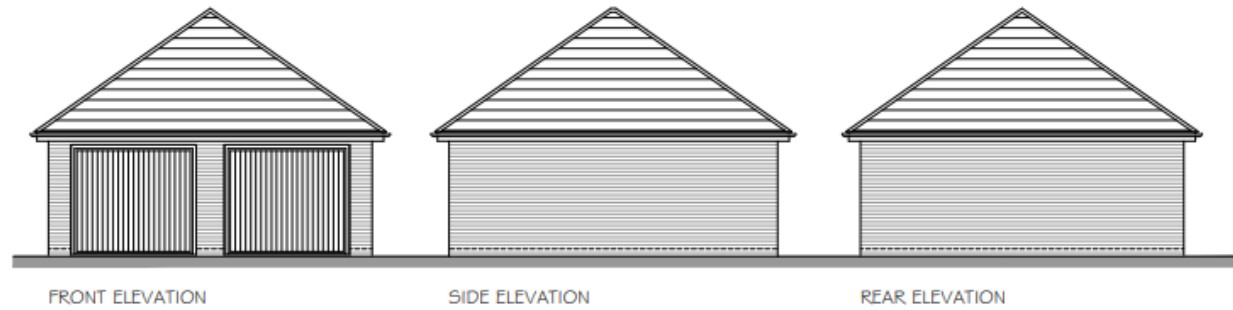
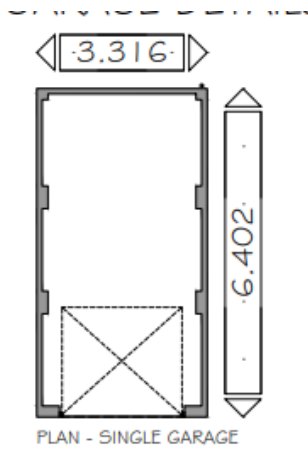
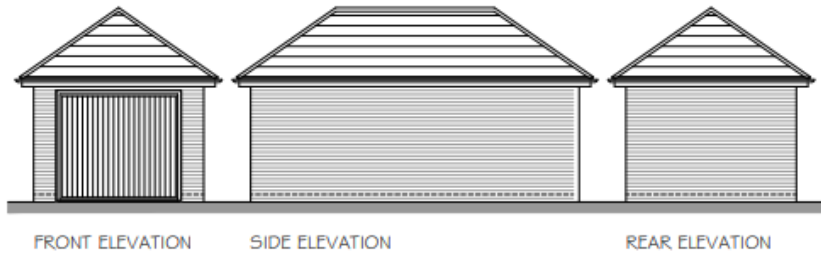

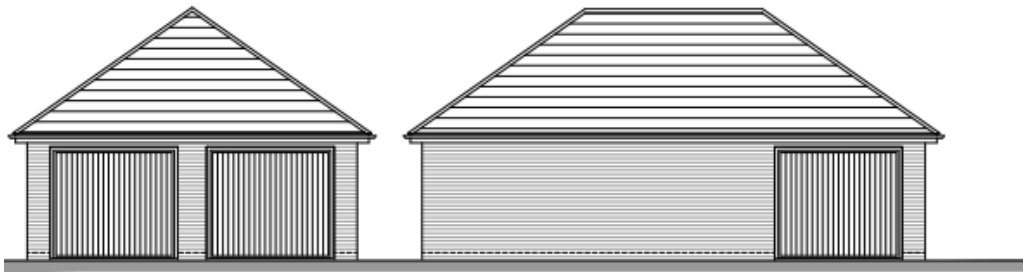

FRONT ELEVATION

SIDE ELEVATION

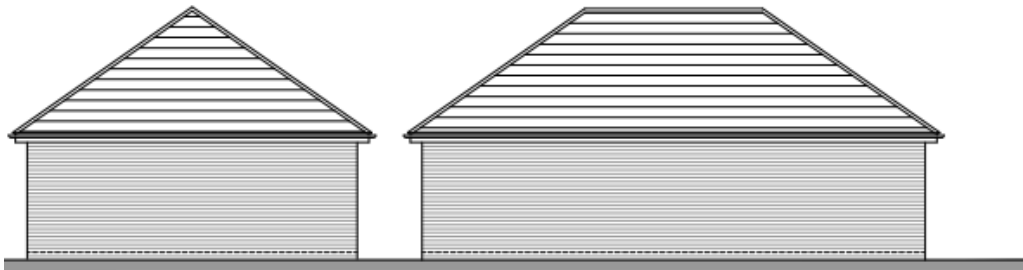

REAR ELEVATION

SIDE ELEVATION

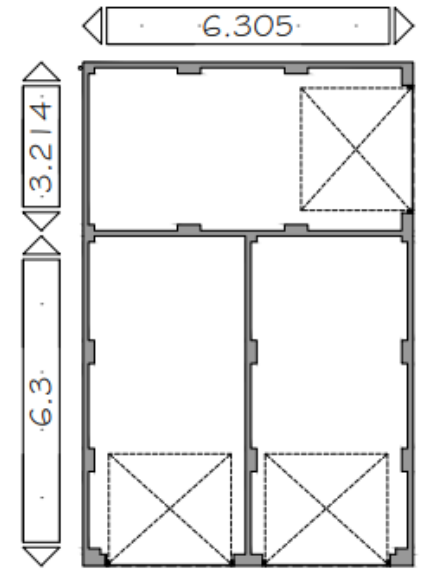

PLAN - TWIN / SINGLE GARAGE



HT - 18 Plot 8 PL - 81-83  
 HT - 18 Plot 9 PL - 81-83  
 HT - Dairy Plot 2 PL - 81-83  
 HT - Markenagh Plot 1 PL - 81-83  
 HT - Markenagh Plot 7 PL - 81-83  
 HT - Dairy Plot 21 PL - 81-83  
 HT - Dairy Plot 22 PL - 81-83  
 HT - Dairy Plot 18 PL - 81-83  
 HT - Markenagh Plot 12 PL - 81-83

Street Scene 1



HT - Markenagh Plot 27 PL - 82-82  
 HT - Dairy Plot 24 PL - 82-82  
 HT - Dairy Plot 24 PL - 82-82  
 HT - Dairy Plot 25 PL - 82-82  
 HT - Dairy Plot 14 PL - 82-75  
 HT - Dairy Plot 15 PL - 82-82  
 HT - Dairy Plot 14 PL - 82-82  
 HT - Dairy Plot 15 PL - 82-82  
 HT - Dairy Plot 12 PL - 82-82  
 HT - Dairy Plot 13 PL - 82-82  
 HT - Dairy Plot 8 PL - 82-82  
 HT - Dairy Plot 9 PL - 82-82

Street Scene 2



HT - 18 Plot 11 PL - 82-82  
 HT - 18 Plot 10 PL - 82-82  
 HT - 18 Plot 6 PL - 81-83  
 HT - 18 Plot 5 PL - 81-83  
 HT - 18 Plot 4 PL - 81-83  
 HT - Dairy Plot 2 PL - 81-83

Street Scene 3



No 108 Park Road  
 No 112 Park Road  
 HT - Markenagh Plot 26 PL - 82-82  
 No 114 Park Road

Street Scene 4



Site photos Poyle road

[Previous](#)

[Next](#)

[Home](#)



Site Photos

[Previous](#)

[Next](#)

[Home](#)





Site Photos

[Previous](#)

[Next](#)

[Home](#)



Site photos

Previous

Next

Home



Site Photos

[Previous](#)

[Next](#)

[Home](#)

# POYLE ROAD, TONGHAM

